

**P Package**  
**3-Lead Plastic TO-3P (Similar to TO-247)**  
 (Reference LTC DWG # 05-08-1450)

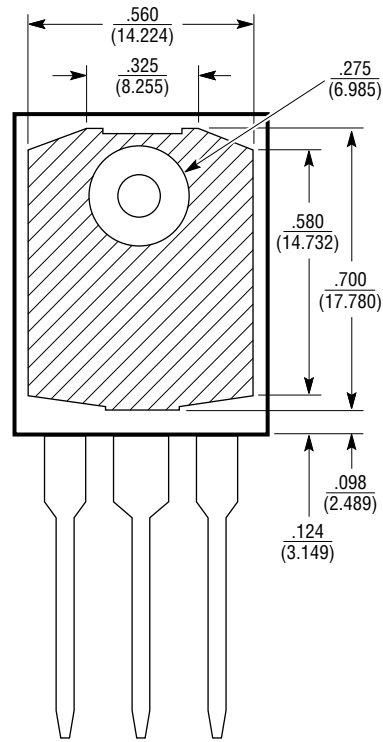

BOTTOM VIEW OF TO-3P  
 HATCHED AREA IS SOLDER PLATED  
 COPPER HEAT SINK

