

# APPLICATION NOTE 105: Current Sense Circuit Collection

## Fault Sensing

The lack of current flow or the dramatic increase of current flow very often indicates a system fault. In these circuits it is important to not only detect the condition, but also ensure the safe operation of the detection circuitry itself. System faults can be destructive in many unpredictable ways.

To see other chapters in this Application Note, return to the [Introduction](#).

## High Side Current Sense and Fuse Monitor

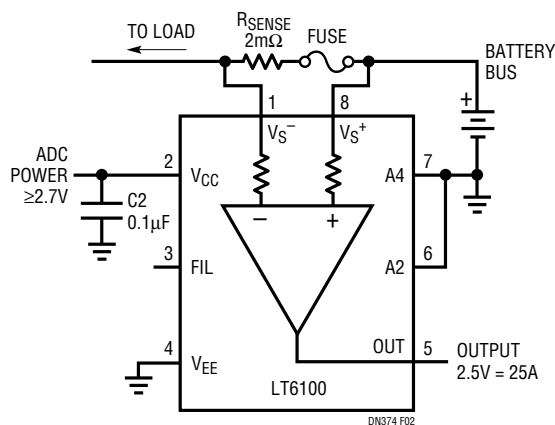

The LT6100 can be used as a combination current sensor and fuse monitor. This part includes on-chip output buffering and was designed to operate with the low supply voltage ( $\geq 2.7V$ ), typical of vehicle data acquisition systems, while the sense inputs monitor signals at the higher battery bus potential. The LT6100 inputs are tolerant of large input differentials, thus allowing the blown-fuse operating condition (this would be detected by an output full-scale indication). The LT6100 can also be powered down while maintaining high impedance sense inputs, drawing less than  $1\mu A$  max from the battery bus.

## Schottky Prevents Damage During Supply Reversal

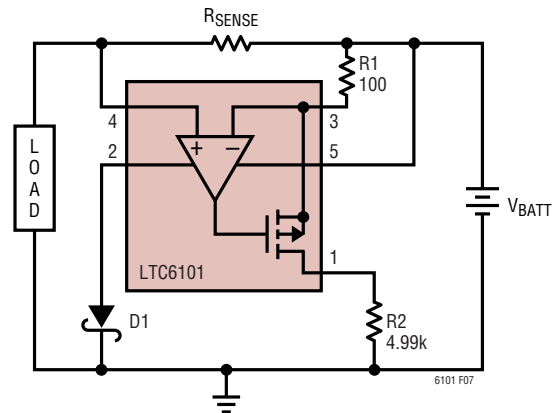

The LTC6101 is not protected internally from external reversal of supply polarity. To prevent damage that may occur during this condition, a Schottky diode should be added in series with  $V^-$ . This will limit the reverse current through the LTC6101. Note that this diode will limit the low voltage performance of the LTC6101 by effectively reducing the supply voltage to the part by  $V_D$ .

## Additional Resistor R3 Protects Output During Supply Reversal

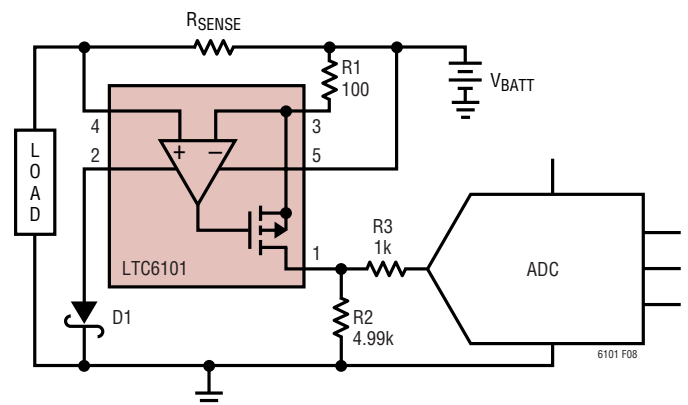

If the output of the LTC6101 is wired to an independently powered device that will effectively short the output to another rail or ground (such as through an ESD protection clamp) during a reverse supply condition, the LTC6101's output should be connected through a resistor or Schottky diode to prevent excessive fault current.

# APPLICATION NOTE 105: Current Sense Circuit Collection

## Electronic Circuit Breaker

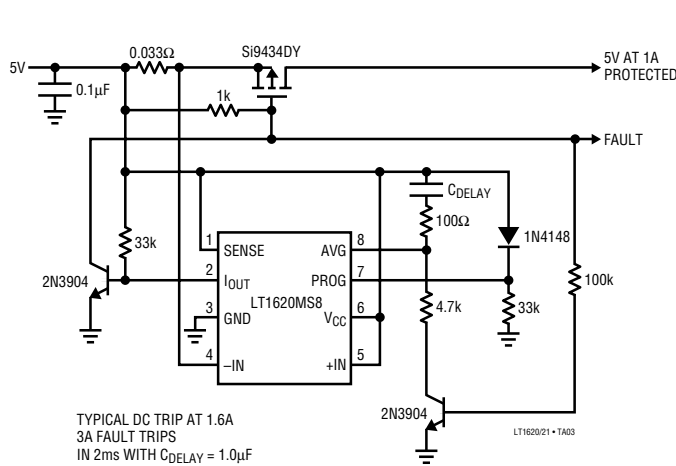

The LT1620I current sense amplifier is used to detect an over-current condition and shut off a P-MOSFET load switch. A fault flag is produced in the over-current condition and a self-reset sequence is initiated.

## Electronic Circuit Breaker

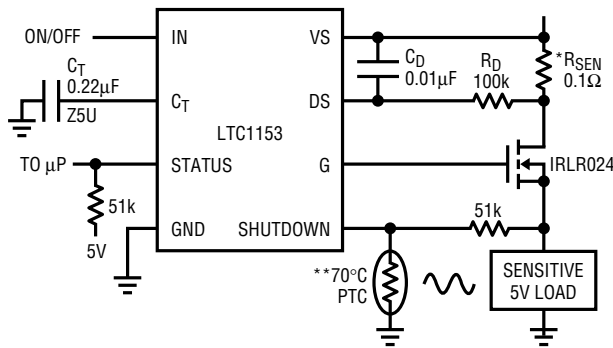

ALL COMPONENTS SHOWN ARE SURFACE MOUNT.  
 \* IMS026 INTERNATIONAL MANUFACTURING SERVICE, INC. (401) 683-9700  
 \*\* RL2006-100-70-30-PT1 KEYSTONE CARBON COMPANY (814) 781-1591

The LTC1153 is an Electronic Circuit Breaker. Sensed current to a load opens the breaker when 100mV is developed between the supply input, VS, and the Drain Sense pin, DS. To avoid transient, or nuisance trips of the break components RD and CD delay the action for 1msec. A thermistor can also be used to bias the Shutdown input to monitor heat generated in the load and remove power should the temperature exceed 70°C in this example. A feature of the LTC1153 is timed Automatic Reset which will try to re-connect the load after 200msec using the 0.22μF timer capacitor shown.

## 1.25V Electronic Circuit Breaker

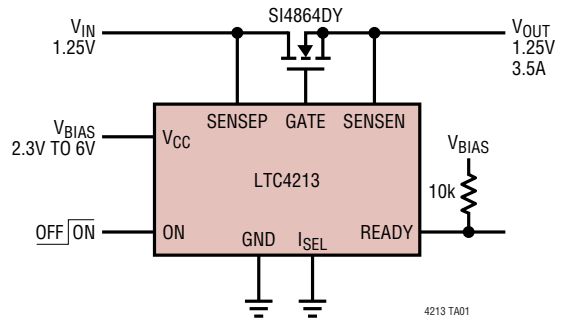

The LTC4213 provides protection and automatic circuit breaker action by sensing Drain-to-Source voltage-drop across the NMOSFET. The sense inputs have a Rail-to-Rail common mode range, so the circuit breaker can protect bus voltages from 0V up to 6V. Logic signals flag a trip condition (with the READY output signal) and reinitialize the breaker (using the ON input). The ON input may also be used as a command in a “smart switch” application.

## Lamp Outage Detector

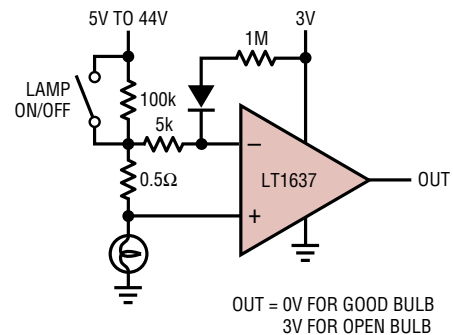

In this circuit, the lamp is monitored in both the on and off condition for continuity. In the off condition, the filament pull-down action creates a small test current in the 5kΩ that is detected to indicate a good lamp. If the lamp is open, the 100kΩ pull-up, or the relay contact, provides the op-amp bias current through the 5kΩ, that is opposite in polarity. When the lamp is powered and filament current is flowing, the drop in the 0.05Ω sense resistor will exceed that of the 5kΩ and a lamp-good detection will still occur. This circuit requires particular Over-the-Top input characteristics for the op-amp, so part substitutions are discouraged (however, this same circuit also works properly with an LT1716 comparator, also an Over-the-Top part).

# APPLICATION NOTE 105: Current Sense Circuit Collection

## Simple Telecom Power Supply Fuse Monitor

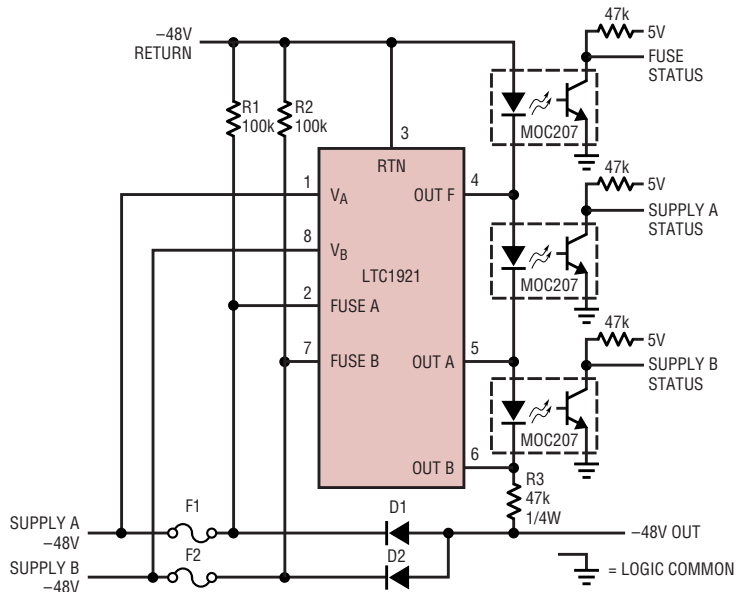

V <sub>A</sub>	V <sub>B</sub>	SUPPLY A STATUS	SUPPLY B STATUS
OK	OK	0	0
OK	UV OR OV	0	1
UV OR OV	OK	1	0
UV OR OV	UV OR OV	1	1

OK: WITHIN SPECIFICATION  
 OV: OVERVOLTAGE  
 UV: UNDERVOLTAGE

V <sub>FUSE A</sub>	V <sub>FUSE B</sub>	FUSE STATUS
= V <sub>A</sub>	= V <sub>B</sub>	0
= V <sub>A</sub>	≠ V <sub>B</sub>	1
≠ V <sub>A</sub>	= V <sub>B</sub>	1
≠ V <sub>A</sub>	≠ V <sub>B</sub>	1*

0: LED/PHOTODIODE ON  
 1: LED/PHOTODIODE OFF  
 \*IF BOTH FUSES (F1 AND F2) ARE OPEN,  
 ALL STATUS OUTPUTS WILL BE HIGH  
 SINCE R3 WILL NOT BE POWERED

The LTC1921 provides an all-in-one telecom fuse and supply-voltage monitoring function. Three opto-isolated

status flags are generated that indicate the condition of the supplies and the fuses.

## Conventional H-Bridge Current Monitor

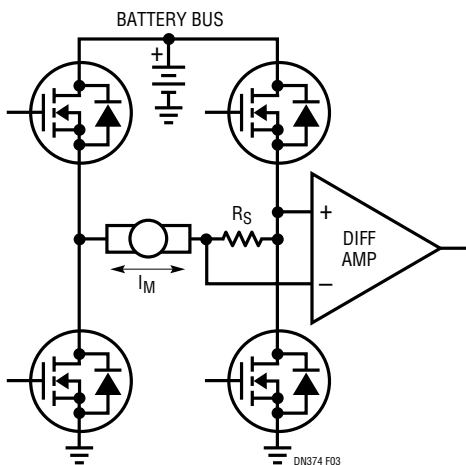

Many of the newer electric drive functions, such as steering assist, are bidirectional in nature. These functions are generally driven by H-bridge MOSFET arrays using pulse-width-modulation (PWM) methods to vary the commanded torque. In these systems, there are two main purposes for current monitoring. One is to monitor the current in the load, to track its performance against the desired command (i.e., closed-loop servo law), and another is for fault detection and protection features.

A common monitoring approach in these systems is to amplify the voltage on a “flying” sense resistor, as shown. Unfortunately, several potentially hazardous fault scenarios go undetected, such as a simple short to ground at a motor terminal. Another complication is the noise introduced by the PWM activity. While the PWM noise may be filtered for purposes of the servo law, information useful for protection becomes obscured. The best solution is to simply provide two circuits that individually protect each half-bridge and report the bidirectional load current. In some cases, a smart MOSFET bridge driver may already include sense resistors and offer the protection features needed. In these situations, the best solution is the one that derives the load information with the least additional circuitry.

# APPLICATION NOTE 105: Current Sense Circuit Collection

## Single Supply 2.5V Bidirectional Operation with External Voltage Reference and I/V Converter

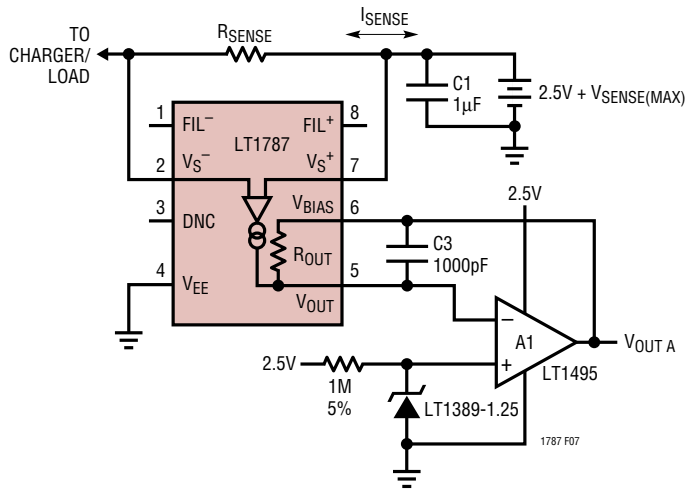

The LT1787's output is buffered by an LT1495 rail-to-rail op-amp configured as an I/V converter. This configuration is ideal for monitoring very low voltage supplies. The LT1787's V<sub>OUT</sub> pin is held equal to the reference voltage appearing at the op amp's non-inverting input. This allows one to monitor supply voltages as low as 2.5V. The op-amp's output may swing from ground to its positive supply voltage. The low impedance output of the op amp may drive following circuitry more effectively than the high output impedance of the LT1787. The I/V converter configuration also works well with split supply voltages.

## Fast Current Sense with Alarm

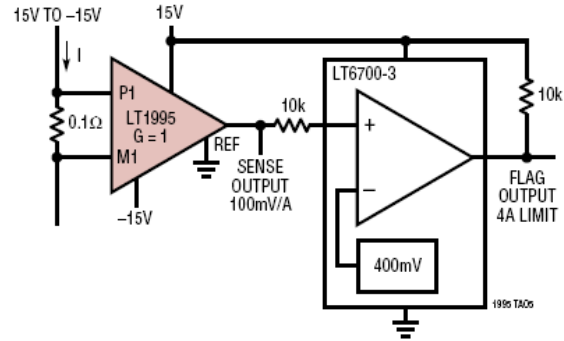

The LT1995 is shown as a simple unity gain difference amplifier. When biased with split supplies the input current can flow in either direction providing an output voltage of 100mV per Amp from the voltage across the 100mΩ sense resistor. With 32MHz of bandwidth and 1000V/usec slew rate the response of this sense amplifier is fast. Adding a simple comparator with a built in reference voltage circuit such as the LT6700-3 can be used to generate an over-current flag. With the 400mV reference the flag occurs at 4A.

## Battery Current Monitor

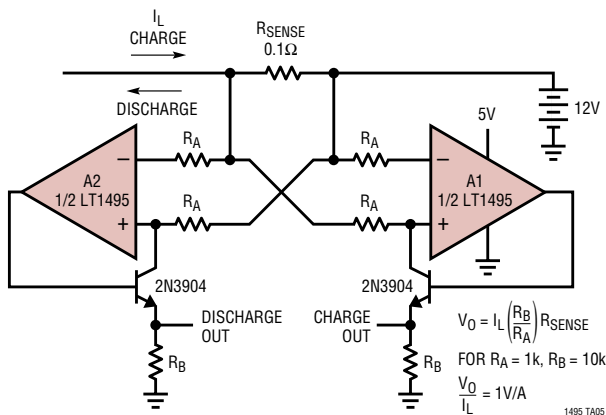

One LT1495 dual op-amp package can be used to establish separate charge and discharge current monitoring outputs. The LT1495 features Over-the-Top operation allowing the battery potential to be as high as 36V with only a 5V amplifier supply voltage.