

APPLICATION NOTE 105: Current Sense Circuit Collection

Motors and Inductive Loads

The largest challenge in measuring current through inductive circuits is the transients of voltage that often occur. Current flow can remain continuous in one direction while the voltage across the sense terminals reverses in polarity.

To see other chapters in this Application Note, return to the [Introduction](#).

Electronic Circuit Breaker

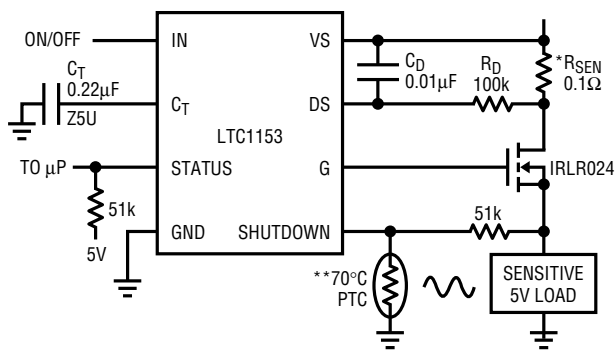

ALL COMPONENTS SHOWN ARE SURFACE MOUNT.
* IMS026 INTERNATIONAL MANUFACTURING SERVICE, INC. (401) 683-9700
** RL2006-100-70-30-PT1 KEYSTONE CARBON COMPANY (814) 781-1591

LTC1153 • TA01

The LTC1153 is an Electronic Circuit Breaker. Sensed current to a load opens the breaker when 100mV is developed between the supply input, Vs, and the Drain Sense pin, DS. To avoid transient, or nuisance trips of the break components RD and CD delay the action for 1msec. A thermistor can also be used to bias the Shutdown input to monitor heat generated in the load and remove power should the temperature exceed 70°C in this example. A feature of the LTC1153 is timed Automatic Reset which will try to re-connect the load after 200msec using the 0.22µF timer capacitor shown.

Conventional H-Bridge Current Monitor

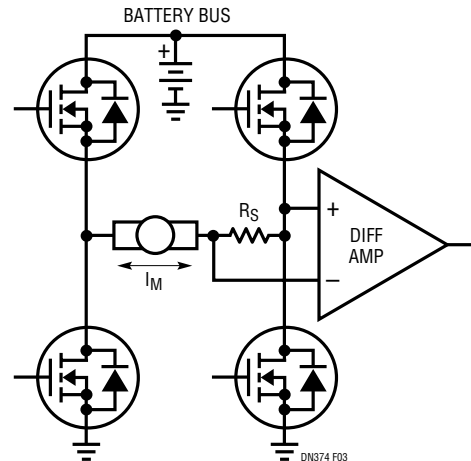

Many of the newer electric drive functions, such as steering assist, are bidirectional in nature. These functions are generally driven by H-bridge MOSFET arrays using pulse-width-modulation (PWM) methods to vary the commanded torque. In these systems, there are two main purposes for current monitoring. One is to monitor the current in the load, to track its performance against the desired command (i.e., closed-loop servo law), and another is for fault detection and protection features.

A common monitoring approach in these systems is to amplify the voltage on a “flying” sense resistor, as shown. Unfortunately, several potentially hazardous fault scenarios go undetected, such as a simple short to ground at a motor terminal. Another complication is the noise introduced by the PWM activity. While the PWM noise may be filtered for purposes of the servo law, information useful for protection becomes obscured. The best solution is to simply provide two circuits that individually protect each half-bridge and report the bidirectional load current. In some cases, a smart MOSFET bridge driver may already include sense resistors and offer the protection features needed. In these situations, the best solution is the one that derives the load information with the least additional circuitry.

APPLICATION NOTE 105: Current Sense Circuit Collection

Lamp Driver

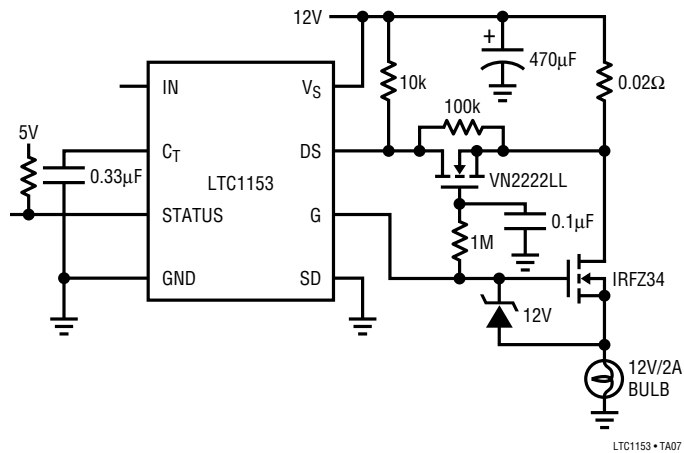

The inrush current created by a lamp during turn-on can be 10 to 20 times greater than the rated operating current. This circuit shifts the trip threshold of an LTC1153 Electronic Circuit Breaker up by a factor of 11:1 (to 30A) for 100ms while the bulb is turned on. The trip threshold then drops down to 2.7A after the inrush current has subsided.

Relay Driver

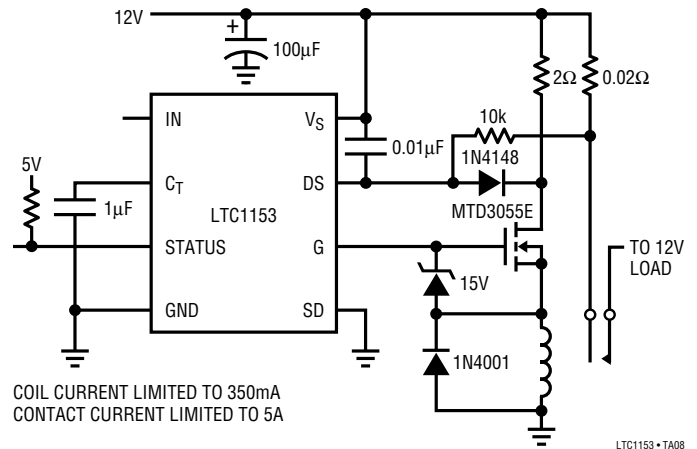

This circuit provides reliable control of a relay by using an Electronic Circuit Breaker circuit with two-level over-current protection. Current flow is sensed through two separate resistors, one for the current into the relay coil and the other for the current through the relay contacts. When 100mV is developed between the Vs supply pin and the Drain Sense pin, DS, the N-channel MOSFET is turned off opening the contacts. As shown, the relay coil current is limited to 350mA and the contact current to 5 Amps.

Intelligent High Side Switch

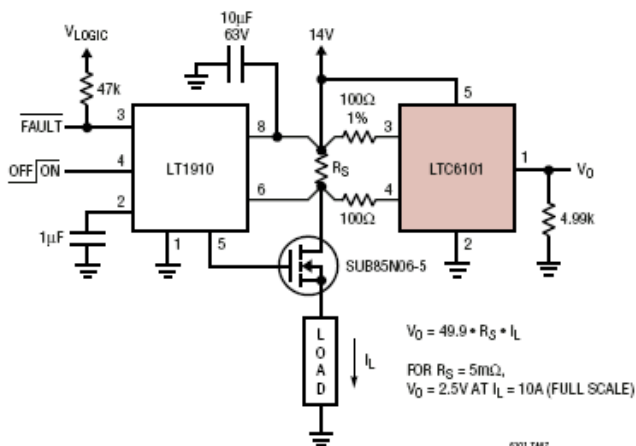

The LT1910 is a dedicated high side MOSFET driver with built in protection features. It provides the gate drive for a power switch from standard logic voltage levels. It provides shorted load protection by monitoring the current flow to through the switch. Adding an LTC6101 to the same circuit, sharing the same current sense resistor, provides a linear voltage signal proportional to the load current for additional intelligent control.

APPLICATION NOTE 105: Current Sense Circuit Collection

Full-Bridge Load Current Monitor

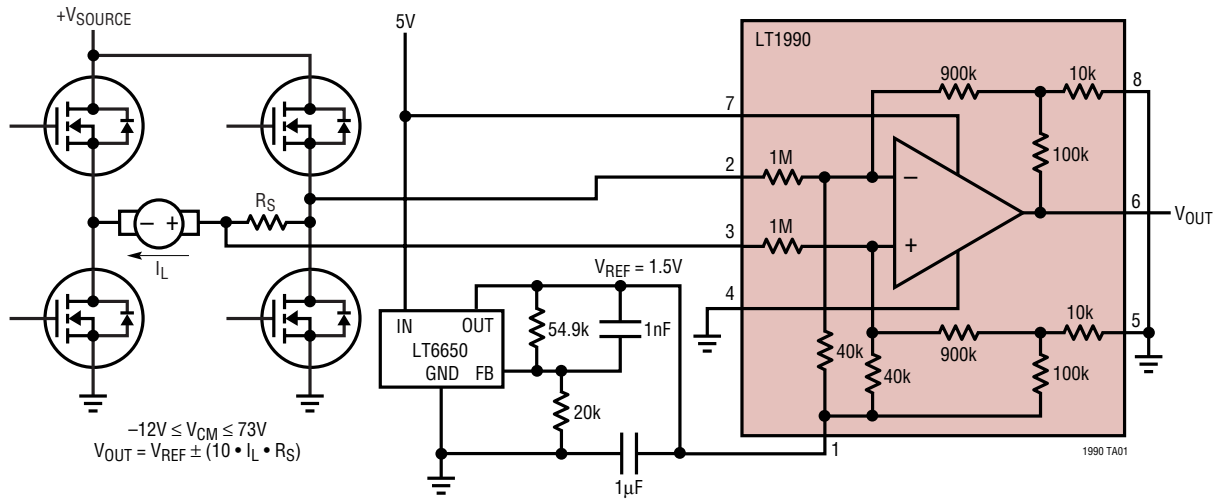

The LT1990 is a difference amplifier that features a very wide common mode input voltage range that can far exceed its own supply voltage. This is an advantage to reject transient voltages when used to monitor the current in a full bridge driven inductive load such as a motor. The LT6650 provides a voltage reference of 1.5V to bias up

the output away from ground. The output will move above or below 1.5V as a function of which direction the current in the load is flowing. As shown, the amplifier provides a gain of 10 to the voltage developed across resistor R_S .